



Specification For Approval

Customer name : _____

Product name : Meat Probe Thermistor Sensor

Customer PN : _____

MFG PN : CWFB1503HD3-301S2M1

MFG			Customer Confirmation		
Make	Check	Approval	Test	Check	Approval

(Company name)

Confirm got the spec and accept as our company's warehouse accept standard.

Version	Revise content	Forwarder	Date
A/1	Just made	Cheng	2017-03-03



1、Overall Dimension

(Unit: mm)

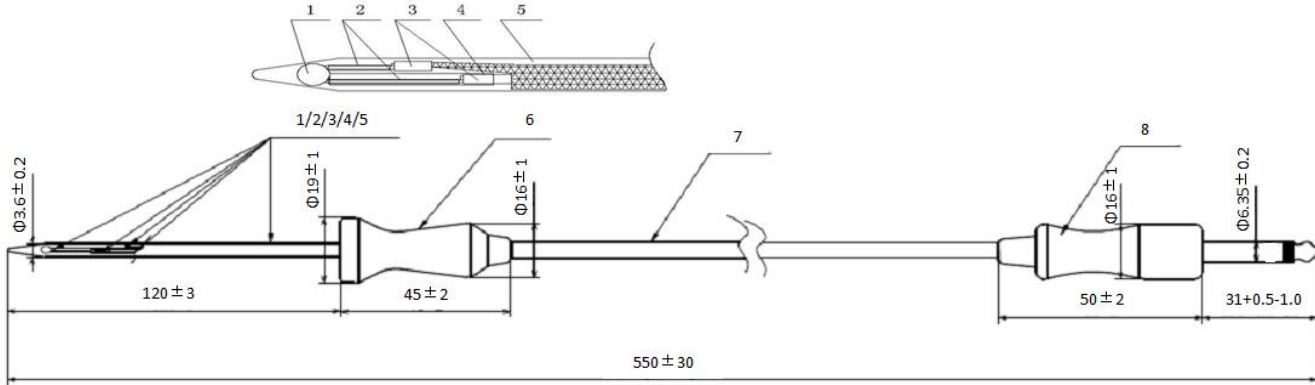

2、Material Explanation

NO	COMPONENT	MATERIAL AND SPECIFICATIONS	Q'TY
2-1.	ELEMENT	B0/100 = 3970 K ± 2% R100 = 3.3 kΩ ± 2.5%	1
2-2.	Casing	Teflon spaghetti sleeving	2
2-3.	Terminals	Brass Tin Plated	2
2-4.	Casing	Teflon spaghetti sleeving	2
2-5.	Housing	Φ3.6 SUS304 Stainless steel	1
2-6.	Handles	Silica gel set	1
2-7.	Lead wire	UL#22 silicone shielded wire	1
2-8.	Plug	Silica gel set 6.35mm	1

3、Part Number :

CWF - $\frac{x}{2}$ $\frac{x}{3}$ $\frac{xxx}{4}$ $\frac{x}{5}$ $\frac{xx}{6}$ $\frac{xxxx}{7}$ $\frac{xxxx}{8}$

- (1) NTC Thermistor Mark;
- (2) Head shape sign (B:Housing Type, D:Dip-Coating, M:Molding);
- (3) Series Type (0:Epoxy coating structure, 1:Epoxy coating structure(high temp)) ;
- (4) Nominal Resistance at 25°C (previous two digits are significant figures, The last digit specifies the number of zeros to follow.);
- (5) Resistance tolerance (%) ;
- (6) B Value code;
- (7) Length Sign (unit is mm) ;



(8) Special code ;

4、Electrical Performance:

NO	Item	Sign	Test Conditions	Min.	Normal value	Max.	Unit
4-1.	Resistance at 100°C	R100	Ta=100±0.10°C P _T ≤0.1mw	3.218	3.300	3.383	kΩ
4-2.	B Value	B0/100	$B=LN \frac{R_{T1}}{R_{T2}} / \left(\frac{1}{T1} - \frac{1}{T2} \right)$	3890.6	3970	4049.4	k
4-3.	Dissipation factor	σ	Ta=25°C (in air)	Approx 5.0			mW/°C
4-4.	Time constant	τ	25°C→100°C T1=25+(100-25)*63.2% =72.4°C (Under water)	Approx 12.0			sec
4-5.	Insulation resistance	/	500VDC 5Sec	≥100			MΩ
4-6.	MAX. Rated power	/	25°C	95			mW
4-7.	Hi-Pot Test	/	1200V AC 1Sec	Max.1.0			mA
4-8.	Operating temp.range	/	/	-30 ~ +250			°C

5、Reliability Test

NO	Item	Technical requirements	Test conditions and method
5-1.	High temp. Storage	ΔR/R25≤±3% ΔB/B≤±3% No change with withstand voltage、 Insulation performance。 Appearance without damage.	150°C±5°C,1000±24H, 200°C±5°C,150±2H (With reference to the IEC60068-2-2/GB2423.2 test)
5-2.	Low temp. Storage		-40°C±5°C,500±24H (With reference to the IEC60068-2-1/GB2423.1 test)
5-3.	Endure moisture test		Store in environment 40±5°C,90%-95%RH for 1000±24 hrs (With reference to the IEC60068-2-3/GB2423.1 test)
5-4.	Temp. cycle test		-40±2°C×30min→ 25±2°C×5min→ in 180±5°C ×30min→25±2°C×5min × 5 cycles
5-5.	Tensile tests		Applying 1 kg force lasts 1 min.
5-6.	Drop test		Free fall into wood floor from height 1M , 3 cycle。



6、 Storage Method

6.1 In the process of storage and transportation, per stack height is not more than 4 CTN products.

6.2 Available with all transport method, but avoid the rain, snow or direct or indirect leaching and mechanical damage.

6.3 Products should be stored in the temperature of environment - 10 °C / + 40 °C, relative humidity is not more than 75%, environment should not have acid, alkali and corrosion gas or radioactive source.

6.4 Storage Time: 1 Year

7、 R—T Table : Pls ref to attachment

Dongguan Tianrui Electronics Co., Ltd

Tel: +86-769-82398812